

SDL3 - Sport Dash Logger

Part No. 18017

Part No. 18018 Backlit version

Basic Specifications

Logging

- Optional 16 MB or 120 MB logging memory
- Logging rates up to 500 samples per second
- Fast Ethernet download

Display

- 70 segment bar graph
- 13 digit alphanumeric text bar
- 48 user-defined, scrollable message lines with programmable overrides
- 3 programmable 'pages' for Practice, Warm-Up and Race

Inputs

- 8 x Analogue voltage inputs, some are high resolution inputs
- 4 x Analogue temperature inputs
- 2 x Digital inputs
- 4 x Speed inputs with voltage measuring capability
- Compatible with up to two E888 expanders (8 Thermocouples only)

Outputs

- 4 x PWM, switched or digital outputs

Internal Sensors

- 3-axis G sensor
- Dash temperature sensor
- Sensor supply voltage
- Battery voltage

Communications

- 2 x CAN with individually programmable CAN bus speeds
- 1 x RS232

(Continued on next page)

The **Sport Dash Logger (SDL3)** comes standard as a combined display and powerful control device in one lightweight unit. With the addition of the Data Logging upgrade it becomes a fully programmable data logger with a 16 or 120 MB memory.

It offers the same construction and advanced technology as the top of the line ADL3, with a package of features tailored to more moderate system requirements.

The screen layout is fully configurable to display a multitude of data channels, warning alarms, lap times, fuel calculations, minimum corner speeds, maximum straight speeds and more.

The SDL3 performs calculations, acquiring data from other MoTeC devices such as an ECU.

Features

- All-in-one display, logger and controller
- Suitable for bikes, cars, marine and industrial applications
- Compact, durable and reliable unit
- Supports wideband Lambda from MoTeC PLMs or LTCs
- Easily integrated with MoTeC CAN-based expanders, lap timing devices, shift lights and ECUs
- Adjustable Backlight (Part No. 18018 only)



SDL3 - Sport Dash Logger

Part No. 18017

Part No. 18018 Backlit version

Physical

- Dimensions 180 x 91 x 18 mm excluding connector
- Weight 385 g
- 1 x 37 pin Autosport connector

Additional Information

Compatibility

- MoTeC ECUs: M4, M48, M8, M400, M600, M800 and M880
- MoTeC Accessories: MDD, E888, SLM, PLM, LTC, BR2, PDM, GPS, etc.
- Many non-MoTeC devices

PC Recommendations

- 32 bit operating system: Windows XP, Vista or Windows7
- Screen size: 1024 x 768
- Processor speed: 1-2 GHz Pentium
- 2 GB RAM
- 256 MB graphics card
- 2 USB ports, 1 Ethernet port

This will ensure it will run all MoTeC software.

Accessories

- Standard Ethernet cable
- Any one of the following Ethernet to Autosport connections:
 - #62202 SDL3 loom
 - #61131 Ethernet cable unterminated, 2 metre
 - #61132 Ethernet to Autosport pins cable, 1.8 metre

Upgrades

- Data Logging 16 MB: Allows recording of all input data to a 16 MB internal logging memory
- Memory 120 MB: Increases the internal logging memory to 120 MB (Requires the Data Logging 16 MB upgrade).
- Pro Analysis: Provides access to advanced *i2 Pro* data analysis software.

Software

- Windows-based software designed for setup and management of the display and data logging system.
- Generate a configuration file offline and then send this to the SDL3
- Calculations including lap times, lap gain/loss, speed and distance, fuel prediction
- Monitor active channels
- Sensor zeroing
- Including details editor
- Extensive help screens

User Manual and Software

Latest versions available from
www.motec.com/downloads.

Connector and Pinout

Pin	Name	Function
1	AV5	Analogue Voltage Input 5
2	AV6	Analogue Voltage Input 6
3	BAT+	Battery Positive
4	BAT-	Battery Negative
5	AUX1	Auxiliary Output 1
6	AUX2	Auxiliary Output 2
7	AUX3	Auxiliary Output 3
8	AUX4	Auxiliary Output 4
9	E-RX-	Ethernet Receive -
10	E-TX-	Ethernet Transmit -
11	SPD3	Speed Input 3
12	SPD4	Speed Input 4
13	8V	Sensor 8 V
14	5V	Sensor 5 V
15	AV1	Analogue Voltage Input 1
16	AV2	Analogue Voltage Input 2
17	AV3	Analogue Voltage Input 3
18	AV4	Analogue Voltage Input 4
19	AV7	Analogue Voltage Input 7
20	AV8	Analogue Voltage Input 8

Pin	Name	Function
21	AT1	Analogue Temp Input 1
22	AT2	Analogue Temp Input 2
23	SPD1	Speed Input 1
24	E-RX+	Ethernet Receive +
25	E-TX+	Ethernet Transmit +
26	SPD2	Speed Input 2
27	DIG1	Digital Input 1
28	DIG2	Digital Input 2
29	CAN1L	CAN 1 Low
30	CAN1H	CAN 1 High
31	AT3	Analogue Temp Input 3
32	AT4	Analogue Temp Input 4
33	TX	RS232 Output
34	RX	RS232 Input
35	CAN0L	CAN 0 Low
36	CAN0H	CAN 0 High
37	0V	Sensor 0 V

Dimensions and Mounting Details

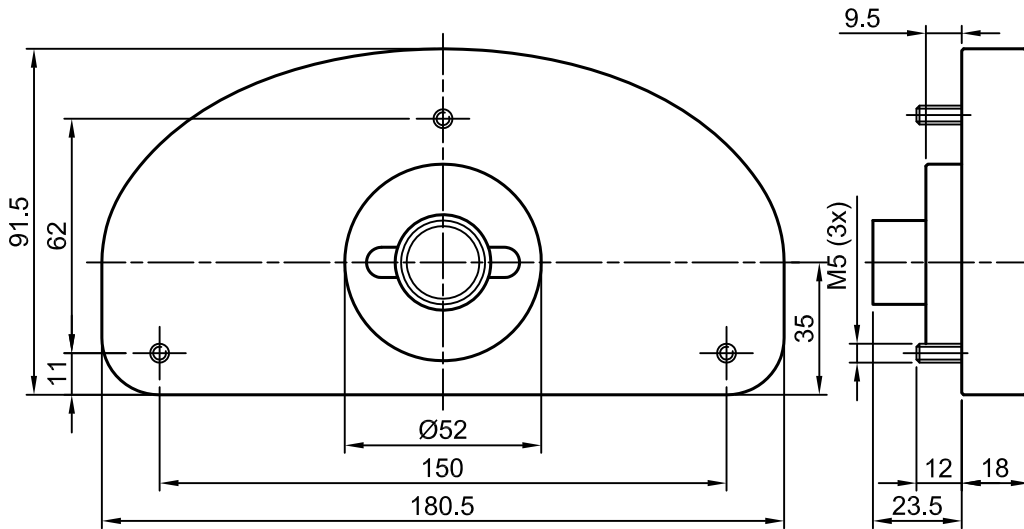

Note:

- All dimensions in [mm]
- Ensure product is not stressed when mounted
- Dimensions indicate actual product size, allow for clearance when mounting

Wiring

Ethernet wiring

SDL3		MoTeC loom colour	Ethernet Connector	
Pin	Function		Pin	Function
24	Ethernet RX+	orange/white	1	Ethernet TX+
9	Ethernet RX-	orange	2	Ethernet TX-
25	Ethernet TX+	green/ white	3	Ethernet RX+
10	Ethernet TX-	green	6	Ethernet RX-

Pin numbering

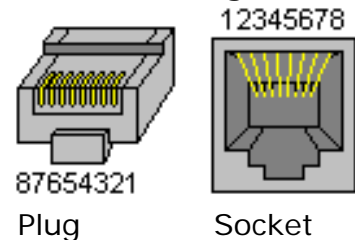

Note: Cat 5 Ethernet cable must be used.

ECU wiring

- When using an M4, M48 or M8 ECU, the SDL3 should be connected via RS232.
- The SDL3 should be connected via the CAN bus when using a 'hundred series' ECU M400/ M600/M800/M880 and any number of other CAN devices. See the following example.

Detailed wiring information is available in the user manual at www.motec.com/downloads.

