

**EDL3 - Enclosed Dash Logger**  
Part No. #18016**Basic Specifications****Logging**

- 16 MB standard logging memory (250 MB optional)
- Logging rates up to 1000 samples per second
- Fast Ethernet download

**Inputs**

- 10 x Analogue voltage inputs (24 optional)
- 4 x Analogue temperature inputs (8 optional)
- 4 x Digital inputs
- 4 x Speed inputs with voltage measuring capability
- 4 x Switched inputs
- Compatible with VIM input expanders

**Outputs**

- 4 x PWM, digital or switched outputs (8 optional)
- Compatible with up to 2 E888/E816 input/output expanders

**Internal Sensors**

- 3-axis G sensor
- Dash temperature sensor
- Sensor supply voltage
- Battery voltage

**Communications**

- 2 x CAN with individually programmable CAN bus speeds
- 1 x RS232

*(Continued on next page)*



The **Enclosed Dash Logger (EDL3)** is a combined fully programmable data logger and powerful control device in one lightweight unit.

Based on the ADL3, it is supplied in an enclosed unit providing the flexibility to connect a display suitable for your application or to use as a 'black box' type data logger. It provides all the advanced features of MoTeC's ADL3 Dash Logger, including warning alarms, lap times, fuel calculations, minimum corner speeds, maximum straight speeds and more.

The EDL3 performs calculations, acquiring data from other MoTeC devices such as an ECU, Dash Logger and VIMs, which enable it to log more than 300 inputs, including high resolution sensor inputs.

**Features**

- Integrated logger and controller
- Suitable for bikes, cars, marine and industrial applications
- Compact, durable and reliable unit
- Supports wideband Lambda from MoTeC PLMs or LTCs
- Easily integrated with MoTeC CAN-based expanders, lap timing devices, shift lights and ECUs
- More than 300 sensor inputs, using VIM input expanders



## EDL3 - Enclosed Dash Logger Part No. #18016

*(Continued from previous page)*

### Physical

- Dimensions 194.5 x 98 x 14.3 mm excluding connector
- Weight 420 g
- 1 x 79 pin Autosport connector

### Additional Information

#### Compatibility

- ECUs: M4, M48, M8, M400, M600, M800, M880
- Accessories: MDD, VIM, E888, E816, SLM, PLM, LTC, BR2, GPS, Telemetry

#### PC Requirements

- Windows 5(B)/98/Me/NT/2000/XP/Vista
- Ethernet port

#### Accessories

- Standard Ethernet cable
- #61213 ADL3 loom
- #61131 Ethernet cable, unterminated, 2 m

#### User Manual and Software

Latest versions available from  
[www.motec.com/downloads](http://www.motec.com/downloads).

### Upgrades

- Data Logging: Increases the internal logging memory to 250 MB.
- Pro Analysis: Provides access to advanced *i2 Pro* data analysis software.
- Telemetry: Enables transmission of live data from the vehicle.
- Remote Logging: Enables converting telemetry data into a log file.
- 52 I/O: Provides additional input/output functionality consisting of:
  - 14 extra Analogue voltage inputs
  - 4 extra Analogue temperature inputs
  - 4 extra Auxiliary outputs

### Software

- Windows-based software designed for setup and management of the display and data logging system.
- Generate a configuration file offline and then send this to the EDL3
- Calculations including lap times, lap gain/loss, speed and distance, fuel prediction
- Monitor active channels
- Sensor zeroing
- Including details editor
- Extensive help screens

## Connector and Pinout

79 pin Autosport connector

Mating connector: #68086

Pin	Name	Function	Pin	Name	Function
1	AV15	Analogue Voltage Input 15	41	AT7	Analogue Temp Input 7
2	AV16	Analogue Voltage Input 16	42	AT8	Analogue Temp Input 8
3	AV17	Analogue Voltage Input 17	43	0V	Sensor 0 V
4	AV18	Analogue Voltage Input 18	44	5V	Sensor 5 V
5	AV19	Analogue Voltage Input 19	45	AV1	Analogue Voltage Input 1
6	0V	Sensor 0 V	46	AV2	Analogue Voltage Input 2
7	BAT-	Battery Negative	47	AV3	Analogue Voltage Input 3
8	BAT+	Battery Positive	48	AV4	Analogue Voltage Input 4
9	AUX1	Auxiliary Output 1	49	AV5	Analogue Voltage Input 5
10	AUX2	Auxiliary Output 2	50	AV6	Analogue Voltage Input 6
11	AUX3	Auxiliary Output 3	51	0V	Sensor 0 V
12	AUX4	Auxiliary Output 4	52	DIG1	Digital Input 1
13	AUX5	Auxiliary Output 5	53	DIG2	Digital Input 2
14	AUX6	Auxiliary Output 6	54	DIG3	Digital Input 3
15	AUX7	Auxiliary Output 7	55	DIG4	Digital Input 4
16	AUX8	Auxiliary Output 8	56	0V	Sensor 0 V
17	0V	Sensor 0 V	57	SW1	Switch Input 1
18	5V	Sensor 5 V	58	SW2	Switch Input 2
19	AV7	Analogue Voltage Input 7	59	SW3	Switch Input 3
20	AV8	Analogue Voltage Input 8	60	SW4	Switch Input 4
21	AV9	Analogue Voltage Input 9	61	0V	Sensor 0 V
22	AV10	Analogue Voltage Input 10	62	8V	Sensor 8 V
23	AV11	Analogue Voltage Input 11	63	SPD1	Speed Input 1
24	AV12	Analogue Voltage Input 12	64	SPD2	Speed Input 2
25	AV13	Analogue Voltage Input 13	65	SPD3	Speed Input 3
26	AV14	Analogue Voltage Input 14	66	SPD4	Speed Input 4
27	0V	Sensor 0 V	67	E-TX+	Ethernet Transmit +
28	5V	Sensor 5 V	68	E-TX-	Ethernet Transmit -
29	AV21	Analogue Voltage Input 21	69	AV20	Analogue Voltage
30	AV22	Analogue Voltage Input 22	70	TX	RS232 Output
31	AV23	Analogue Voltage Input 23	71	0V	0 V CAN
32	AV24	Analogue Voltage Input 24	72	8V	8 V CAN
33	0V	Sensor 0 V	73	CAN0L	CAN 0 Low
34	AT1	Analogue Temp Input 1	74	CAN0H	CAN 0 High
35	AT2	Analogue Temp Input 2	75	CAN1L	CAN 1 Low
36	AT3	Analogue Temp Input 3	76	CAN1H	CAN 1 High
37	AT4	Analogue Temp Input 4	77	E-RX+	Ethernet Receive +
38	AT5	Analogue Temp Input 5	78	E-RX-	Ethernet Receive -
39	AT6	Analogue Temp Input 6	79	RX	RS232 Input
40	0V	Sensor 0 V			

## Dimensions and Mounting Details

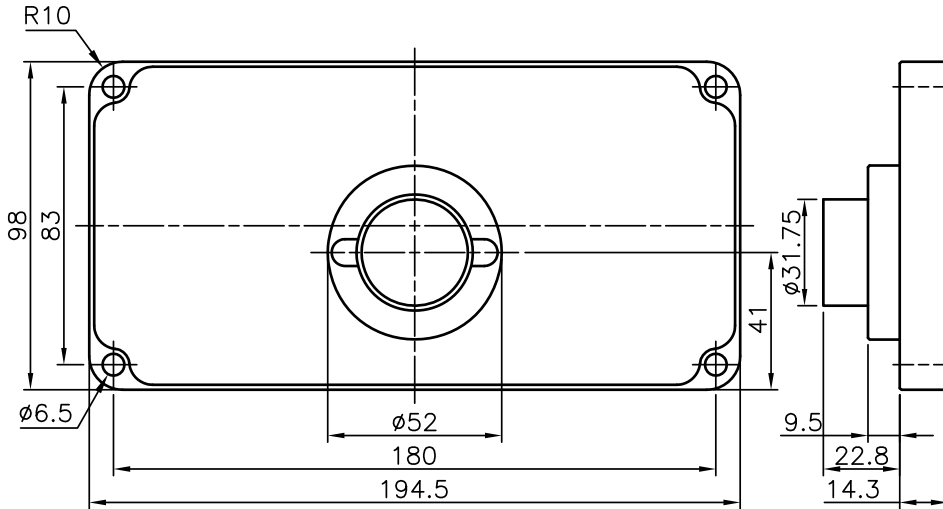

**Note:**

- All dimensions in [mm]
- Ensure product is not stressed when mounted
- Dimensions indicate actual product size, allow for clearance when mounting

## Wiring

### Ethernet wiring

EDL3		Ethernet Connector	
Pin	Function	Pin	Function
67	Ethernet Tx+	1	Ethernet Rx+
68	Ethernet Tx-	2	Ethernet Rx-
77	Ethernet Rx+	3	Ethernet Tx+
78	Ethernet Rx-	6	Ethernet Tx-

### Pin numbering

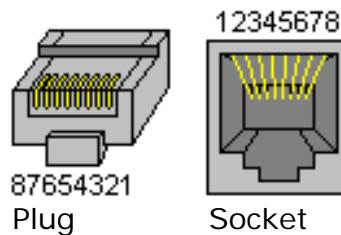

**Note:**

Cat 5 Ethernet cable must be used.

### ECU wiring

- When using an M4, M48 or M8 ECU, the EDL3 should be connected via RS232.
- The EDL3 should be connected via the CAN bus when using a 'hundred series' ECU M400/ M600/M800/M880 and any number of other CAN devices as in the example.

Detailed wiring information is available in the user manual at [www.motec.com/downloads](http://www.motec.com/downloads).

